



SAFE CONVEYOR, INC.

Phone: (508) 689-7849 Email: sales@safeconveyor.com

Safe Conveyor Inc., would like to thank you for the opportunity to introduce our line of technically innovative modular conveyor systems.

As a leader in the manufacturing of safe portable modular conveyors, our goal is to provide conveyors that are designed to be easy to operate and install. With over 25 years of experience, Safe Conveyor is positioned to offer our clients the best of the “next generation” of high-performance and low energy consumption modular conveyor systems that are the safest on the market.

Our universal frame can be a single section conveyor or you can add other sections to create numerous configurations to meet your application.

By purchasing a Safe Conveyor you will receive the following benefits:

- **Quick and Easy to Order**
- **Simple to operate with variable speed “plug & play” drive**
- **Large selections from 6” – 24” wide and lengths as small as 18 inches or up 40 feet long with one motor**
- **Make turns or inclines**
- **Create multi-level systems**

If you have any questions or wish to discuss your application in more detail, please don't hesitate to contact us at: (508) 689-7849, or you may also email at sales@safeconveyor.com.

Sincerely,

Chris Caron
Vice President
Safe Conveyors, Inc.
Phone: (508) 689-7849
Fax: (508) 689-7850
Email: ccaron@safeconveyor.com
Cell: (401) 263-7881

1658 GAR HWY, Suite #2, Swansea, MA 02777 Phone: 508-689-7849 Fax: 508-689-7850

Email: sales@safeconveyor.com

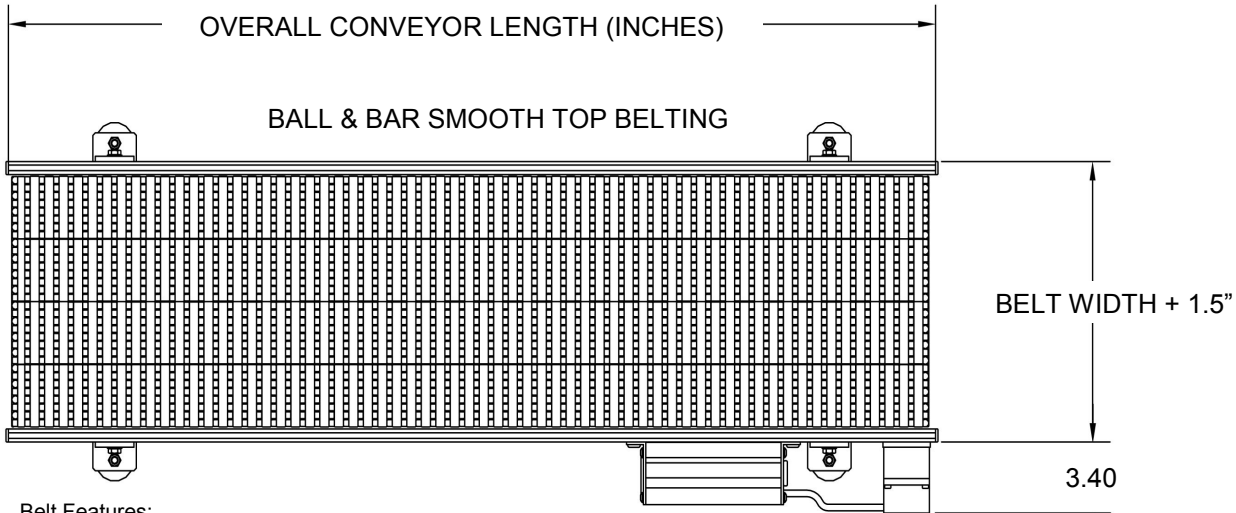
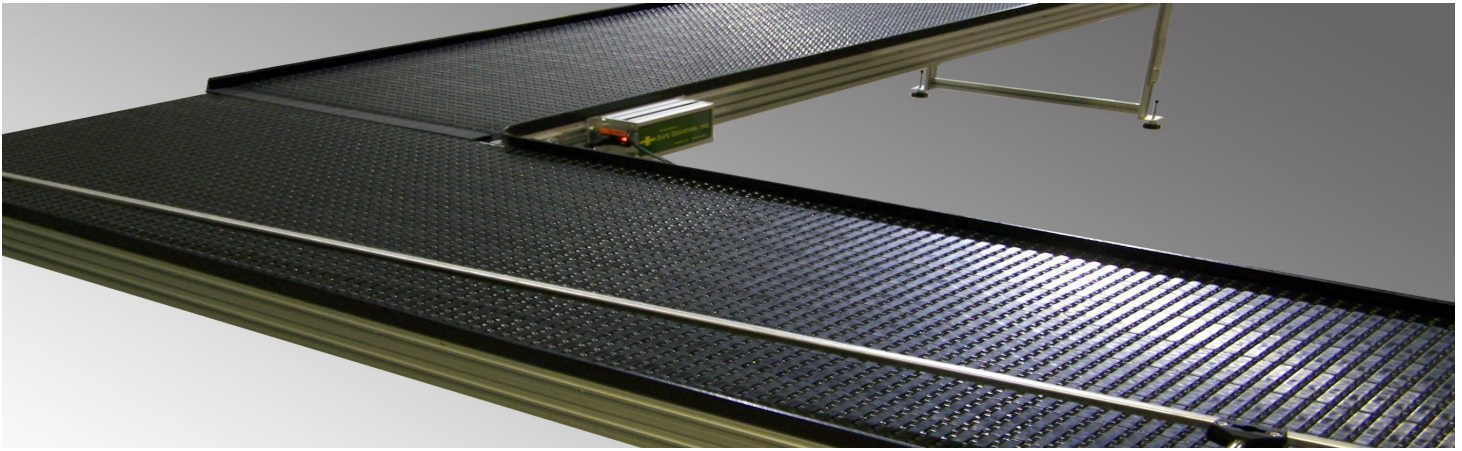

Belt Features:
 Self lubricating long life maintenance free performance.
 Releasably connected construction for easy assembly & removal.
 Smooth non-scuff surface for sliding under packages.
 Black semi-gloss finish is ideal background for inspection.

DIRECT DRIVE MOTOR

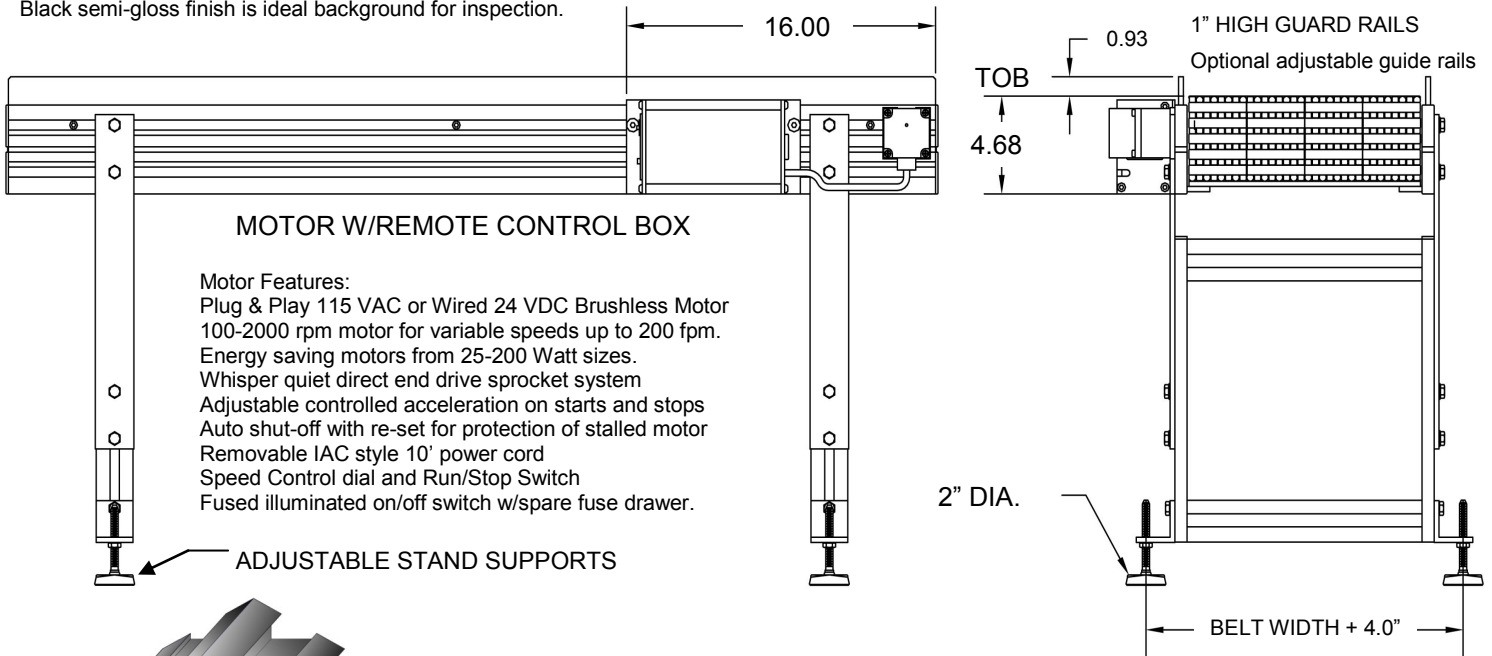

Motor Features:
 Plug & Play 115 VAC or Wired 24 VDC Brushless Motor
 100-2000 rpm motor for variable speeds up to 200 fpm.
 Energy saving motors from 25-200 Watt sizes.
 Whisper quiet direct end drive sprocket system
 Adjustable controlled acceleration on starts and stops
 Auto shut-off with re-set for protection of stalled motor
 Removable IAC style 10' power cord
 Speed Control dial and Run/Stop Switch
 Fused illuminated on/off switch w/spare fuse drawer.

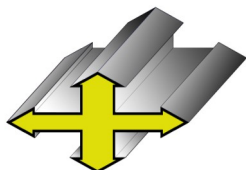

SAFE CONVEYOR, INC.

1658 GAR Hwy STE #2, Swansea, MA 02777

Phone: 508-689-7849, Fax: 508-689-7850, Email: sales@safeconveyor.com