



Corner Turn Installation Instructions

Installation Tools

1. 9/16 Hex Wrench

Read Before Starting

We do not use a front stand on Corner Turn Conveyors less than 24" long. Conveyors are joined and supported on both sides using machined brackets and plates. Please follow these instructions to set up your corner turn system

Joining Corner Turn Sections

1. Set-up the long conveyor with stands per instructions in the owners manual except place the stand at the start of the line approximately 6" further than the width of the in-feeding conveyor. (I.E. If the in-feed conveyor is 12" wide, place the stand on the joining section approximately (6" + 12") 18" from the end.
2. Install one stand on the start of the short conveyor.
3. Loosen bolts on the joining bracket and plate to allow sections to be slid together. (The plate and angle bracket are already pre-installed.)(See Photos)
4. Tighten hardware and install end-to-side transfer plate as shown. (In-feed sections should be slightly higher at turn. Use clearance in joiners to make this adjustment.)



Joiner Plate



Joiner Bracket

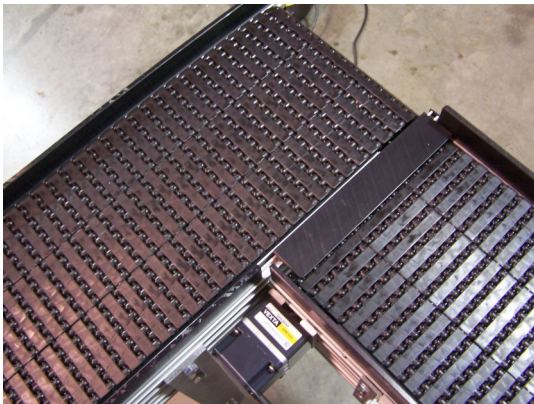

Top View with Transfer Plate Installed



Completed Installation

Safe Conveyor Inc. 1658 GAR Hwy Ste 2, Swansea MA 02777
For more information, please visit our website at safeconveyor.com



SAFE CONVEYOR, INC.

When installing stand at the corner turn joining area, it is important to mount the inside stand upright with only 1 bolt into the lower "T" slot as shown below. Mounting to both "T" slots will allow the upper bolt to rub on the belt of the in feed conveyor.

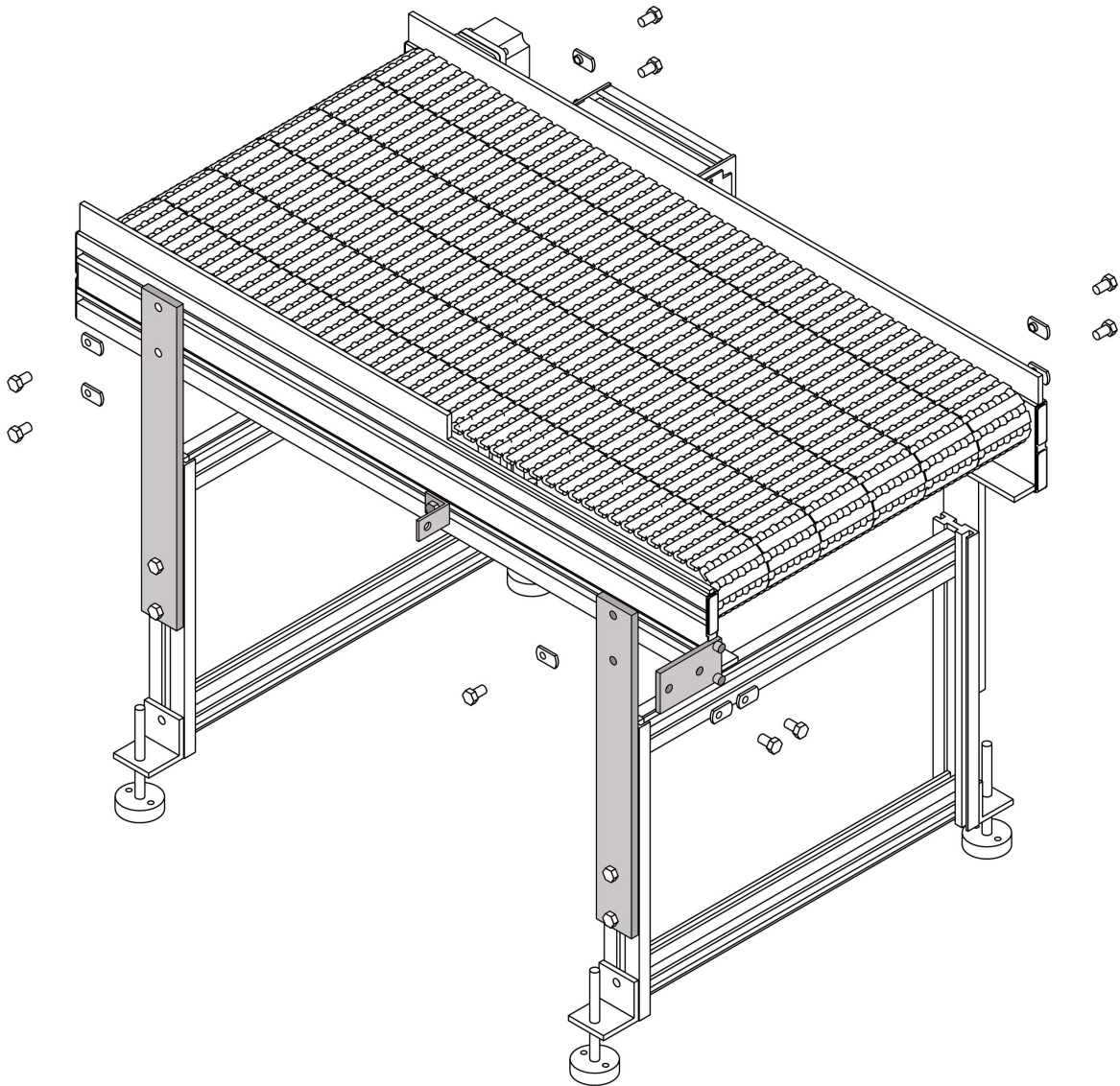

Safe Conveyor Inc. 1658 GAR Hwy Ste 2, Swansea MA 02777
For more information, please visit our website at safeconveyor.com